

REVISION HISTORY			
REV	DESCRIPTION	DATE	BY
1	Updated acc. to standard	14-03-2016	IG
2	Firesafe features revised	20-06-2016	IG

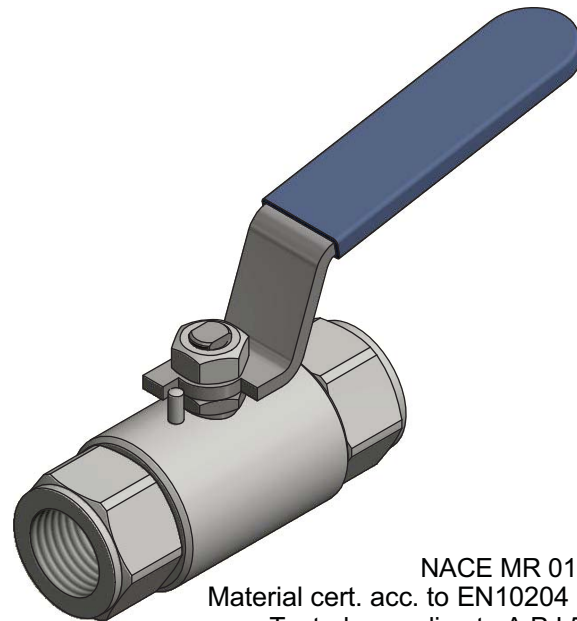

FLOW DIAGRAM

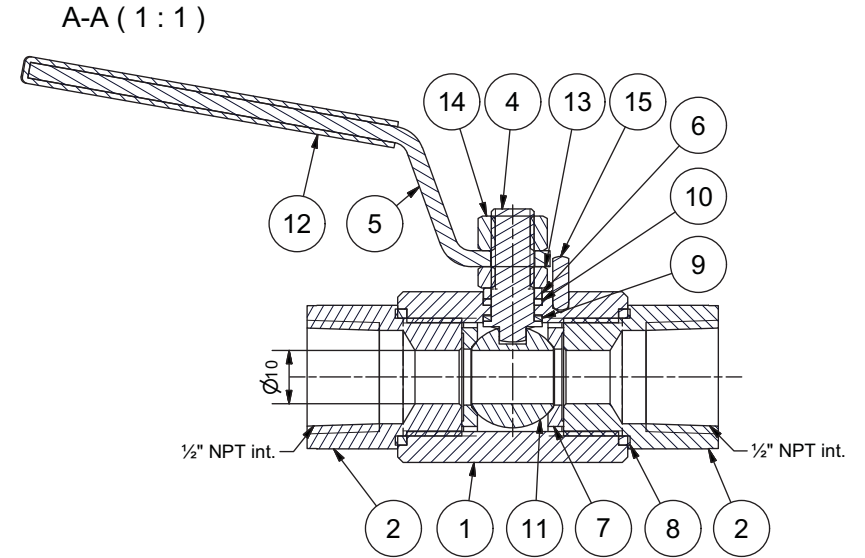
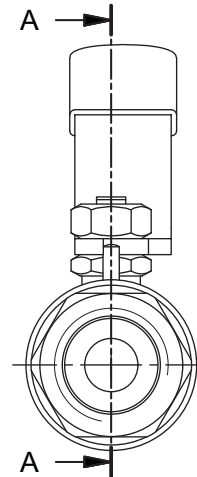
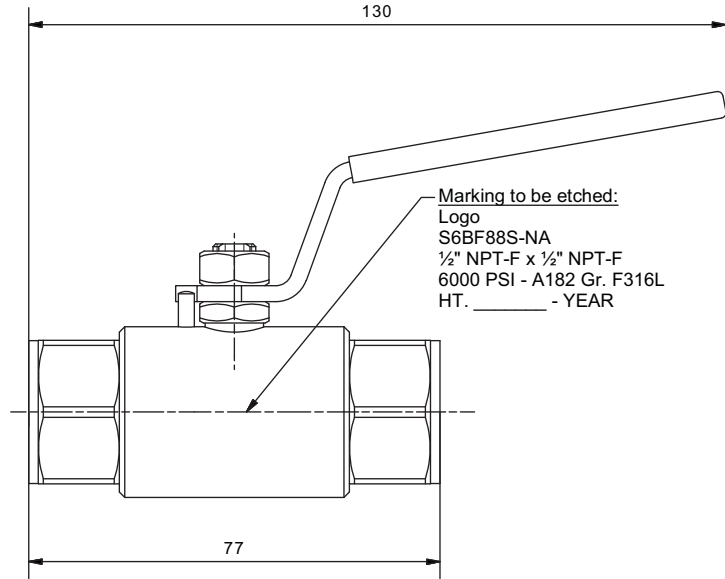
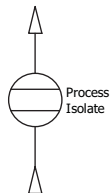

NACE MR 01.75  
Material cert. acc. to EN10204 3.1  
Tested according to A.P.I.598

Parts List					
ITEM	QTY	PART	MATERIAL	DWG/ PART NO.	HEAT NO.
1	1	Housing	A182 Gr. F316L	7-08-0101	
2	2	End Adaptor	A182 Gr. F316L	7-08-0302	
4	1	Spindle	A182 Gr. F316L	7-08-0103	
5	1	Handle	A182 Gr. F316L	7-08-0104	
6	1	Gasket bushing	A182 Gr. F316L	7-08-0105	
7	2	Ball seat	PEEK	7-08-0106	
8	2	Connection gasket	PTFE	7-08-0107	
9	1	Spindle gasket	PTFE 25% glass	7-08-0108	
10	1	Spindle gasket	Graphoil	7-08-0108	
11	1	Ball	A182 Gr. F316L	7-08-0109	
12	1	Handle Sleeve	Vinyl	7-08-0111	
13	1	Nut	A4	M8 - DIN 439B	
14	1	Nut	A4	M8 - DIN 934	
15	1	Pin	A4	Ø3 x 12mm - DIN 1474	

Scale	Size	Date	Sign.	Ball Valve Assembly - 1/2" NPT-F x 1/2" NPT-F		Gen. tolerances: ISO 2768 m
1 : 1	A3	Draw. 28-07-2015	IG			Drawing No.: 7-09-1380-2
Weight: 394,7 g		Check				Order No.: