

Marking to be etched:  
 Logo  
 6000 PSI-AISI316  
 S62NRAF88S  
 1/2" NPT-F x 1/2" NPT-F  
 HT. \_\_\_\_\_ 2014

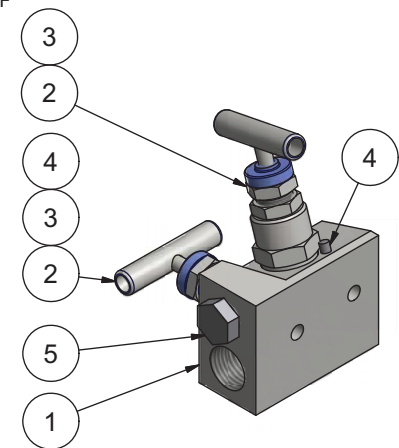

**FLOW DIAGRAM**

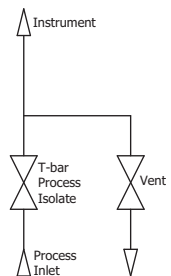

Parts List					
ITEM	QTY	PART	MATERIAL	DWG/ PART NO.	HEAT NO.
1	1	Manifold Housing	AISI 316	07-02-0601	
2	2	Bonnet Type SN - T bar	AISI 316	07-00-0200	
3	2	Gasket	AISI 316	07-00-0209	
4	2	Pin Ø4x10mm	A4		
5	1	Plug 1/4" NPT	AISI 316		

Scale	Size	Date	Sign.	Assembly - 1/2" NPT-F / 1/2" NPT-F	Gen. tolerances: ISO 2768 m
1:2	A3	Draw. 06-03-2014	MP		Drawing No.: 07-02-0910-0
Weight: 0,9 kg	Check				Order No.: