

Marking to be etched:  
 Logo  
 6000 PSI-AISI316  
 S62NRF88S-NA  
 1/2"NPT-F x 1/2"NPT-F  
 HT. \_\_\_\_\_ 2014

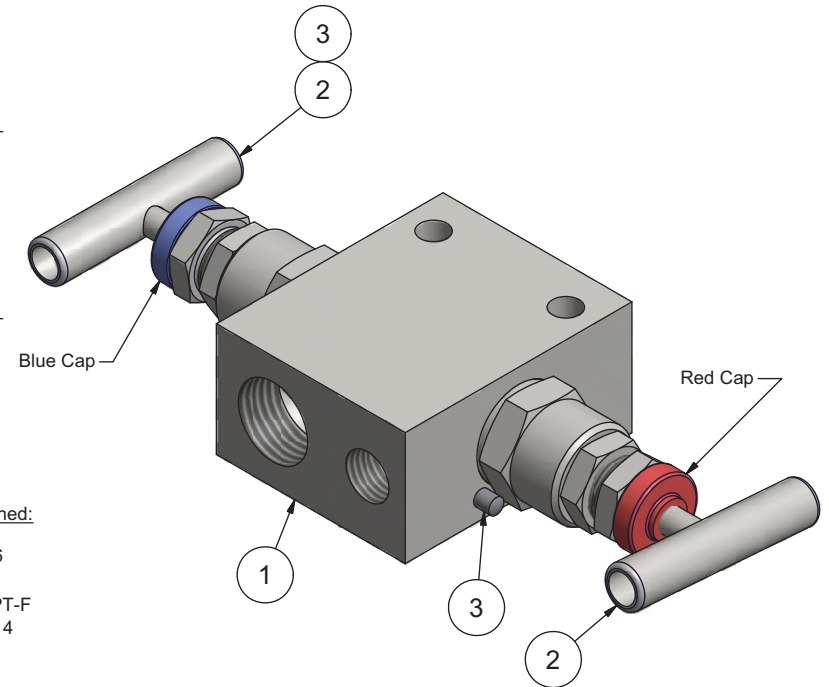

Bonnet gasket material		
Type	Grafoil	PTFE
Process Isolate		x
Vent		x

**FLOW DIAGRAM**

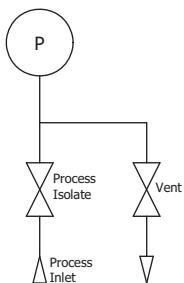

Parts List					
ITEM	QTY	PART	MATERIAL	DWG/ PART NO.	HEAT NO.
1	1	Manifold housing	AISI 316	07-02-1031	
2	2	Bonnet Type SN - T bar	AISI 316	07-00-0200	
3	2	Pin Ø4x10mm	A4		
Included Accessories					
ITEM	QTY	PART	MATERIAL	DWG/ PART NO.	HEAT NO.
4	1	Plug 1/4" NPT	AISI 316	3-09-0202	
Scale	Size	Date	Sign.	Gen. tolerances: ISO 2768 m	
1:1	A3	Draw. 27-08-2014	MP	Drawing No.: 07-02-1030-0	
Weight: 0,9 kg	Check			Order No.:	

Assembly - 1/2" NPT-F / 1/2" NPT-F