

REVISION HISTORY			
REV	DESCRIPTION	DATE	BY
1	Dimensions adjusted	20-10-2015	IG
2	Marking revised	20-01-2016	IG

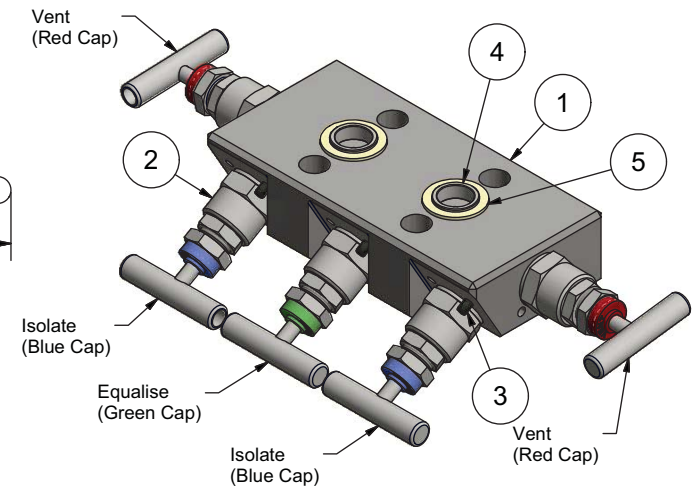

Gasket material		
Type	Grafoil	PTFE
IEC 61518		x
Process Isolate		x
Vent		x
Equalise		x

FLOW DIAGRAM

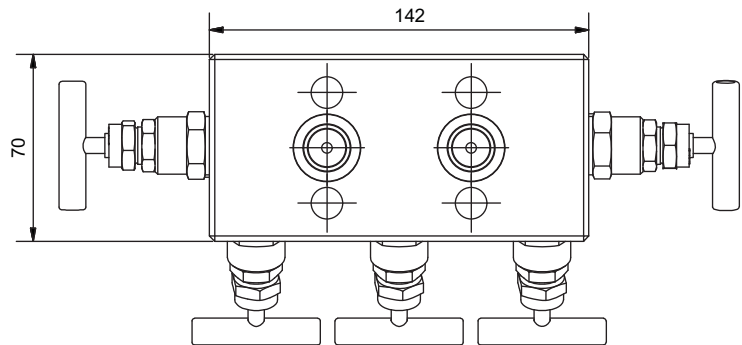
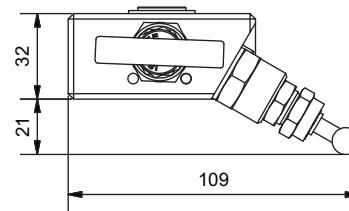
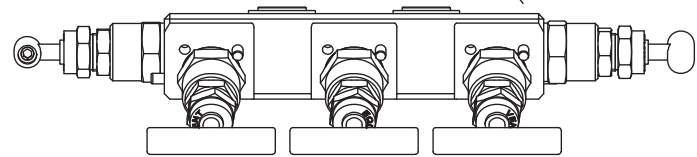
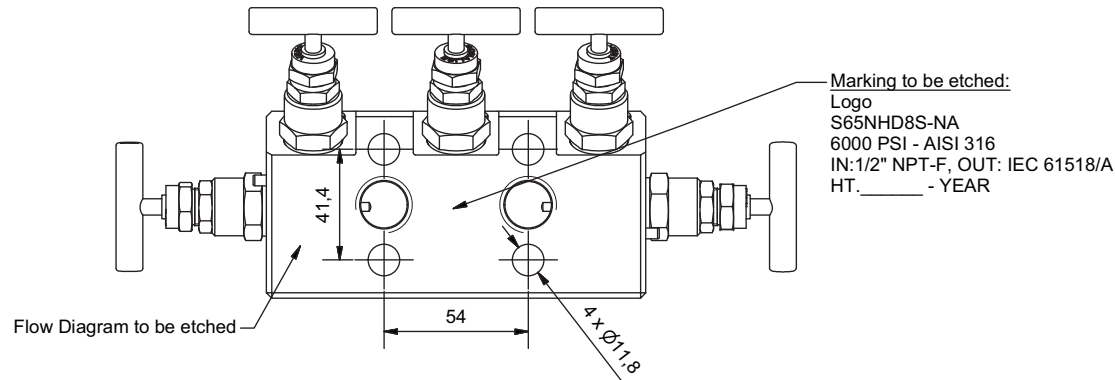
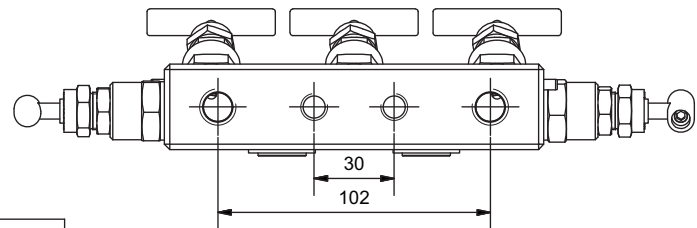
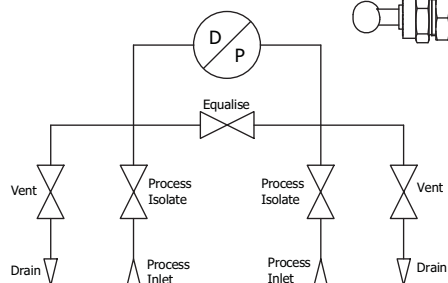

Parts List					
ITEM	QTY	PART	MATERIAL	DWG/ PART NO.	HEAT NO.
1	1	Manifold Housing	AISI 316	7-10-0701	
2	5	Bonnet Type SN - T bar	AISI 316	7-00-0700	
3	5	Pin Ø4x12mm - DIN 1474	A4		
4	2	Spigot	AISI 316	7-00-0600	
5	2	Gasket IEC61518 - Type A		7-00-0601	

Included Accessories					
ITEM	QTY	PART	MATERIAL	DWG/ PART NO.	HEAT NO.
6	2	Plug 1/4" NPT	AISI 316	3-09-0202	
Scale	Size	Date	Sign.	5 Valve Manifold 5T000.3	
1 : 2	A3	Draw. 20-10-2015	IG	Manifold Housing - 5 Valve - 1/2" NPT-F / IEC61518A	
Weight: 3,2 kg	Check			Customer:	Gen. tolerances: ISO 2768 m
				Project:	Drawing No.: 07-10-0750-2
					Order No.:

Tested according to A.P.I.598