

Handle for Anti Tamper Bonnet
AISI316

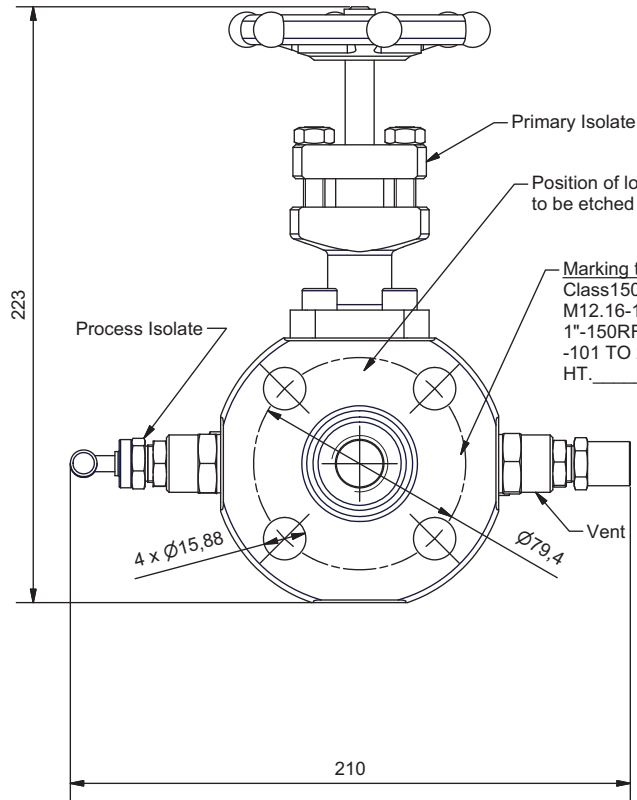

Marking to be etched:
Class150-AISI316
M12.16-150RF8SL-NA-SDBB
1"-150RF x 1/2" NPT-F
-101 TO 204 DEG.C.
HT. _____ 2014

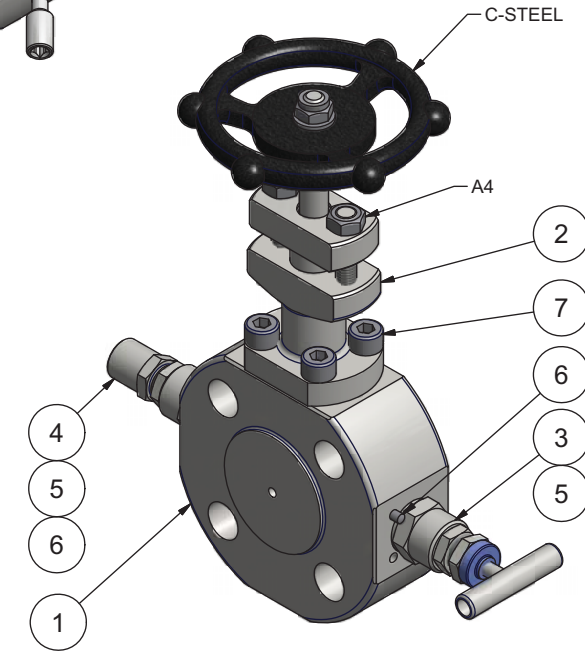
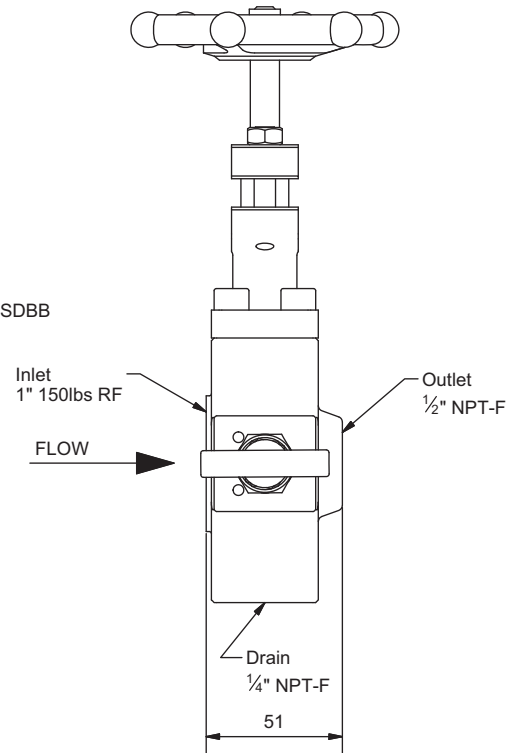

FLOW DIAGRAM

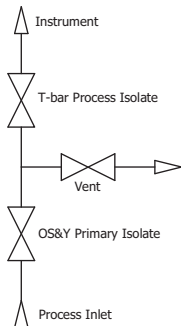

Bonnet gasket material		
Type	Grafoil	PTFE
Primary Isolate	x	
Process Isolate		x
Vent		x

Parts List					
ITEM	QTY	PART	MATERIAL	DWG/ PART NO.	HEAT NO.
1	1	Manifold Housing	AISI 316	07-01-1531	
2	1	Bonnet Type L - OS&Y	AISI 316	07-00-0100	
3	1	Bonnet Type SN - T bar	AISI 316	07-00-0200	
4	1	Bonnet Type AN - Anti tamper	AISI 316	07-00-0300	
5	2	Gasket	AISI 316	07-00-0209	
6	2	Pin Ø4x10mm	A4		
7	4	Socket Head Screw M8x20mm - DIN 912	UNS S32760		
8	2	Pin Ø4x25mm	A4		

Scale	Size	Date	Sign.	Assembly - 1" 150lbs RF / 1/2" NPT-F	Gen. tolerances: ISO 2768 m
1:2	A3	Draw. 18-03-2014	MP		Drawing No.: 07-01-1530-0
Weight: 3,8 kg	Check				Order No.: